



# OXTALES

Newsletter of the Oxley Region Amateur Radio Club Inc.  
 PO Box 712 Port Macquarie 2444

**September 2002**

Compiled by VK2TT

PRESIDENT: Alan Nutt VK2GD 6582.3557  
 VICE PRES: Bill Brooke VK2ZCW 6581.0547  
 TREASURER: John Bailey VK2KHB 6583.9349  
 SECRETARY: Alan Nutt VK2GD 6582.3557

## President's Report

I have more than a sneaking suspicion that I was 'conned' into this position! However that may be, one must rise to the challenge and respond accordingly. My primary concern at the moment is an apparent unwillingness for a member to take up the executive secretary position. I say 'apparent' since not all members were present at the AGM and there may well be some who are still unaware that the position is vacant. If the trend continued, (says he, with tongue in cheek), I could well find myself holding every executive position by default! Absolute power – wonderful stuff .....



Seriously, though, I believe we ought to take to heart this lack of interest facing many clubs, an issue which was addressed in some detail by the Blue Mountains Club in the August issue of "AR". As a starter I have suggested reintroducing regular talks and discussion following our Saturday meetings. After all, we are a hobby club, not a business organization and, hopefully, we are involved because of the enjoyment we get from mixing with others who share with us a common interest in amateur radio. Personally, I don't think there has been one Club meeting where I have not gone away more enlightened on some topic or other. Offers have already been made to speak at the September and October meetings and I look forward to others volunteering something of their knowledge and expertise in

the months to come.

If there *is* no enjoyment, then we have missed the boat and we need to examine both our own attitude and the activities, or lack of them, offered by the Club. It's an old saying but still true that I only get out what I put in. This applies to any similar organization and if my approach is only what I'm going to get out of my club association, then I'm going to be sadly disappointed in the long run.

I'm also aware that many Club members feel they have 'done their stint', sometimes many times over, and the foregoing comments may not apply. But the fact remains – there are important positions needing to be filled if our Club is to remain viable. Let's make a concerted effort this year to breathe some fresh air into our Club – it'll be worth it.

Alan VK2GD

President

### In This Issue :

Item.	Page No.
President's Report	1
Down The Coax	2
AGM Report	2
Net Controller's Roster	2
E-Mail Directory	2
More From VK2BUE	3
Lighthouse Exercise	6
Simple Field Strength Meter	6
Membership Subs Reminder	7
Membership List	8

## Down The Coax

**Friday Night  
Get-together  
Sept 13th & 27th  
7.00pm**

**October Meeting  
Saturday 5th October 2002  
2.00pm**

**Friday Night  
Get-together  
October 11th & 25th  
7.00pm**

**November Meeting  
Saturday 2nd Nov. 2002  
2.00pm**

## AGM Report

Our Annual General Meeting, held on Saturday 3rd August, drew a reasonable attendance.

David (VK2AYD) was elected returning officer and the results of the election of office bearers for the new year was as follows:-

President : Alan Nutt (VK2GD)  
Vice President: Bill Brooke (VK2ZCW)  
Secretary : Alan Nutt (VK2GD) acting until office is permanently filled.  
Treasurer: John Bailey (VK2KHB)

The motion, of which notice was given, to change the club's name, was defeated.

Membership fees remain as for the previous year :-

Full membership: \$25.00  
Associate Membership: \$20.00  
Distant Membership: \$15.00

## Net Controllers Roster.

**Caution!** As from October 27th, the pattern of this roster has changed from that which you saw in previous rosters. The reason ? ... Henry (VK2ZHE) has joined us as a Net Controller and his availability has spread the load a little. Welcome to the ranks of the honourable Net Controllers, Henry!

## Sundays

VK2AIF Sep-01  
VK2FSH Sep-08  
VK2JJ Sep-15  
VK2MAZ Sep-22  
VK2OA Sep-29

## Wednesdays

### September

VK2GD Sep-04  
VK2HBM Sep-11  
VK2EI Sep-18  
VK2EJK Sep-25

### October

VK2ATM Oct-02  
VK2AYD Oct-09  
VK2DAL Oct-16  
VK2EI Oct-23  
VK2HBM Oct-30

### November

VK2EJK Nov-03  
VK2OA Nov-10  
VK2JJ Nov-17  
VK2MAZ Nov-24  
VK2FSH Nov-06  
VK2GD Nov-13  
VK2ATM Nov-20  
VK2ZHE Nov-27

### December

VK2DAL Dec-01  
VK2BZD Dec-08  
VK2TT Dec-15  
VK2OA Dec-22  
VK2AIF Dec-29  
VK2AYD Dec-04  
VK2HOT Dec-11  
VK2MAZ Dec-18  
VK2GD Dec-25

### January

VK2HBM Jan-01  
VK2FSH Jan-05  
VK2JJ Jan-12  
VK2BZD Jan-19  
VK2HOT Jan-26  
VK2EI Jan-08  
VK2EJK Jan-15  
VK2ATM Jan-22  
VK2ZHE Jan-29

### February

VK2AIF Feb-02  
VK2TT Feb-09  
VK2BZD Feb-16  
VK2EJK Feb-23  
VK2AYD Feb-05  
VK2DAL Feb-12  
VK2EI Feb-19  
VK2HBM Feb-26

### March

VK2OA Mar-02  
VK2JJ Mar-09  
VK2MAZ Mar-16  
VK2TT Mar-23  
VK2ZHE Mar-30  
VK2FSH Mar-05  
VK2GD Mar-12  
VK2ATM Mar-19  
VK2AYD Mar-26

## E-mail Directory

(Reflects changes notified up to 02.09.02)

VK2EI (Neil) neilsan@tpg.com.au  
VK2FT (Jason) jasonm@tsn.cc  
VK2GD (Alan) anut@ozemail.com.au  
VK2JB (John) jebaylis@midcoast.com.au  
VK2JJ (John) jjones@felglow.com.au  
VK2OA (Allan) possoa@tsn.cc  
VK2TT (Trevor) gramps@felglow.com.au  
VK2VY (John) vk2vy@bigpond.com  
VK2ATM (Arthur) arfamo@midcoast.com.au

VK2AYD (David) davpil@midcoast.com.au  
VK2CLL (Larry) lindsay@midcoast.com.au  
VK2DAL (David) davsmith@midcoast.com.au  
VK2DDL (Stan) svellis@tsn.cc  
VK2EJK (Bob) bobro@bigpond.com.au  
VK2FSH (Charles) cpedmond@oceania.net  
VK2HBM (Craig) martins@dodo.com.au  
VK2HOT (Bruce) brucew@tsn.cc  
VK2YOR (Roy) rburges@intercoast.com.au  
VK2ZCV (Bill) bilsinvk@fasternet.com.au  
VK2ZCW (Bill) cabrooke@bigpond.com  
VK2ZHE (Henry) lundell@tpg.com.au

### More From VK2BUE (Ernie)

Members will recall the interesting two-part series covering the life story of Ernie (VK2BUE) that we read in recent issues of Oxtales. Well, Ernie has now given us some details of his association with the Fairy Swordfish, an aircraft with which he became very familiar during WW2. Here, again in Ernie's own words, is his account of this association. *(Thanks again Ernie, for another original contribution from a distant member... Ed)*

The first time I saw a Fairy Swordfish was in 1936. Our squadron of Fairy 3F's was being replaced with them

It was larger than the 3F. Its engine was a Bristol Pegasus 775HP, whereas the 3F had a Rolls Royce End Line Type which had a habit of "Big end" failures. Not so with the Pegasus which proved to be a very reliable motor.

We thought it was a very nice looking aircraft. My pilot, a Flying Officer (Royal Air Force) took off from the glorious carrier. He dived it, side slipped it, looped it and then took it up to 21,000 feet and did a power dive and it performed beautifully. He said to me "I can fly it using the ailerons on top of the wing." To tell the story of the Swordfish, the damage this old bi-plane did in WW2 is worth recording.

I guess you all know how the Swordfish attacked the German Battleship "BISMARCK" and put her steering gear out of order so the navy could trap and sink her. But that's not all! During WW2, our convoys were being decimated by U-boats and the situation was pretty grim.

I don't know who suggested the idea to Winston Churchill, but someone pointed out that those fast freighters that brought fruit over from the West Indies—nick-named Banana Boats—could be stripped and the upper deck replaced with a flight deck. In other words,

make them into small aircraft carriers.

But what aircraft was slow enough to land on them. Why! What else but the Swordfish.

So each convoy had four carriers. Each carrier had 4 Swordfish planes which were fitted with 4 depth charges each. A potential of sixty four "Ash Cans".

I guess you all know about the Brits breaking the Enigma Code. So it was known where and when the U-boats would attack. To do this they have to be at periscope depth and are perfectly visible from the air. They didn't know what hit them. Pack after pack got blitzed in this way and the convoys kept getting to their destinations.

The last operation by the Swordfish of 825 Squadron is accounted in the enclosed copy of TAGS, the Journal of The Telegraphist Air Gunners Association. The story, by Roy Gibbs, MID, of Orpington, Kent, is included below:-

*This is the story of the glorious, if ill fated and ill conceived, but famous Channel attack against the Scharnhorst and Gneisnau, two of Germany's most powerful ships. The information has been researched from Ray Sturtivant's book, **British Naval Aviation**, and other sources.*

*After the sinking of the Bismark, the remnants of 825 Squadron, in January 1942, were reforming at Lee on Solent. Fears that the Scharnhorst and Gneisnau would break out, led the squadron moving on the morning of the 4th February, 1942 to RAF Station, Manston. Here they were put on 5 minutes readiness for what was expected to be a night attack.*

*On the morning of 11th February, the German ships took advantage of the poor weather to move out, heavily protected by a destroyer screen and a large fighter aircraft umbrella. By the time Lt. Cmdr. Esmonde, 825's CO, received orders to mount an attack the next morning, they were well up the English Channel. 825 had been promised fighter cover from 411, 64 and 72 RAF squadrons but only 10 fighters from 72 squadron turned up and there were soon heavily engaged in a dog fight with the huge number of FW 190's and*



**A "Swordfish". Ernie flew in this type of aircraft from H.M.S. Glorious.**

*ME 109's to be of much use to the Swordfish.*

*Esmonde led the first sub flight of three into the attack and although his port wing had been shot to ribbons, somehow, made it over the Destroyer and E Boat screen and released his torpedo, after which he was shot down by a FW 190. His TAG, Bill Clinton, was reported by a Spitfire pilot as last seen on the back of the fuselage trying to beat out the flames in the tailplane.*

*The second Swordfish was piloted by Sub. Lt. Rose, whose TAG, Ambrose Johnson had already been killed. Rose himself had already been wounded in the back and moments later a shell splinter fractured his petrol tank. With*

*engine faltering he aimed his torpedo at the Gneisnau and saw it running well at 2000 yards. The Observer, Sub. Lt. Lee was unhurt and tried to take over the TAG's gun, but couldn't move Johnson's body. They crashed into the sea. Lee managed to get Rose out and into the dinghy but Johnson was too firmly wedged in the cockpit and sank with the Swordfish.*

*Sub. Lt. Colin Kingsmill who was piloting the third Swordfish had early in the action been hit in the engine and had the upper port wing on fire. In spite of this the TAG, Don Bunce kept firing and shot down an enemy fighter. After dropping their torpedo at about 3000 yards, they were also shot down. Luckily they were picked up by a British MTB within 10 minutes, as their*

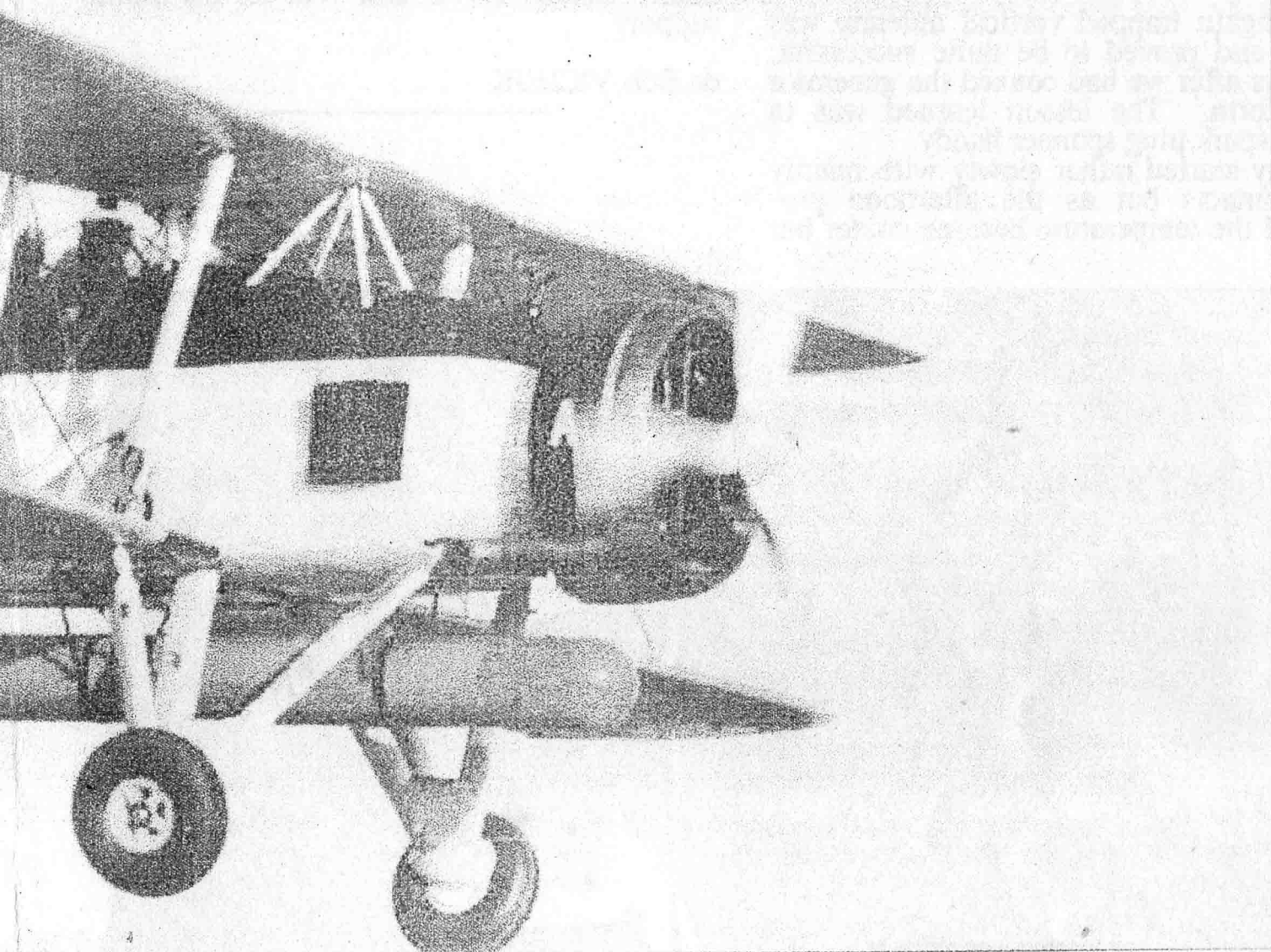

*dinghy had been destroyed by fire.*

*The second sub flight of 3 Swordfish were last seen taking evasion action as it flew into an inferno of anti aircraft fire. There were no survivors to tell the tale.*

*Esmonde was awarded a posthumous Victoria Cross, the 4 surviving officers the DSO and Don Bunce the Conspicuous Gallantry Medal. All the other members of this gallant force who lost their lives were awarded a Mention in Despatches. Admiral Ramsey, Flag Officer Commanding Dover, wrote "In my opinion, the gallant sortie of these six Swordfish constitutes one of the finest exhibitions of self sacrifice and devotion to duty that the war has*

*yet witnessed."*

*It is these chaps we will be commemorating when we lay our wreath on the 14thg March at the FAA Memorial on the Embankment and after at the Stag Lunch.*

*There has been some criticism of the fact that those who lost their lives only got a MID. However, I have been told that this is the only award given posthumously, other than a V.C.*

### **The Lighthouse Exercise**

The annual Lighthouse weekend 18/19th August started of at the clubhouse with

VK2's GD, HOT, ZCV, ZHE, BZD, ZCW, and EJK. Because of the small number of participants available for the latter part of the day it was decided that the setup would be operated from the back of a truck on Saturday and if there were any members interested in the Remembrance Day contest it could be operated from the clubhouse on Sunday.

A Highgain trapped vertical antenna was set up and proved to be quite successful, that was after we had coaxed the generator to perform. The lesson learned was to have a spark plug spanner handy. The day started rather slowly with mainly VK contacts but as the afternoon progressed the temperature became colder but

the calls improved. At 4.36 pm the generator fuel tank was low and hypothermia was taking over so it was called a day. Gear was packed up and returned to the clubroom. The score for the day was 26 which included, the USA, Europe, and New Zealand. A tenacious crew proved that hams can operate under difficult conditions with sadistic enthusiasm, but it was decided to give Sunday a miss. Thanks Trevor and Will for the moral support.

de Bob VK2EJK

---



The Crew in Action

## Simple Field Strength Meter

At a recent meeting, David (VK2AYD) did a "show-and-tell" on the simple field strength meter shown here. With the exception of the 50 uA meter, the components are likely to be available in the junk box or around the shack. Construction of the whole project takes in the order of around 2 hours. It is a handy addition to the shack if you don't already have a similar little device for detecting the presence of RF, and doing relative measurements on your RF generating devices and antennae.

C1,2,3 .01uF  
 D1,2 1N60 Germanium.  
 R1 56K  
 RV1 10K  
 L1 100 uH  
 M 50 uA FSD

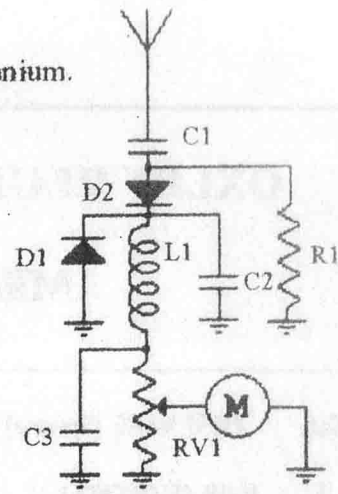

## Annual Membership Subscriptions

At the time of going to press, our membership renewals were "slow" in being presented to our Treasurer. We are now into our 3rd month of the new financial year and despite some new and "returning" members, we are not yet back to our last year's total membership.

If your name does not appear on the membership list on page 8, then it means the Treasurer has not received your renewal subscriptions. In turn, this means that you will be considered an unfinancial member until your annual subscriptions are received. Oxtales is not distributed to unfinancial members.

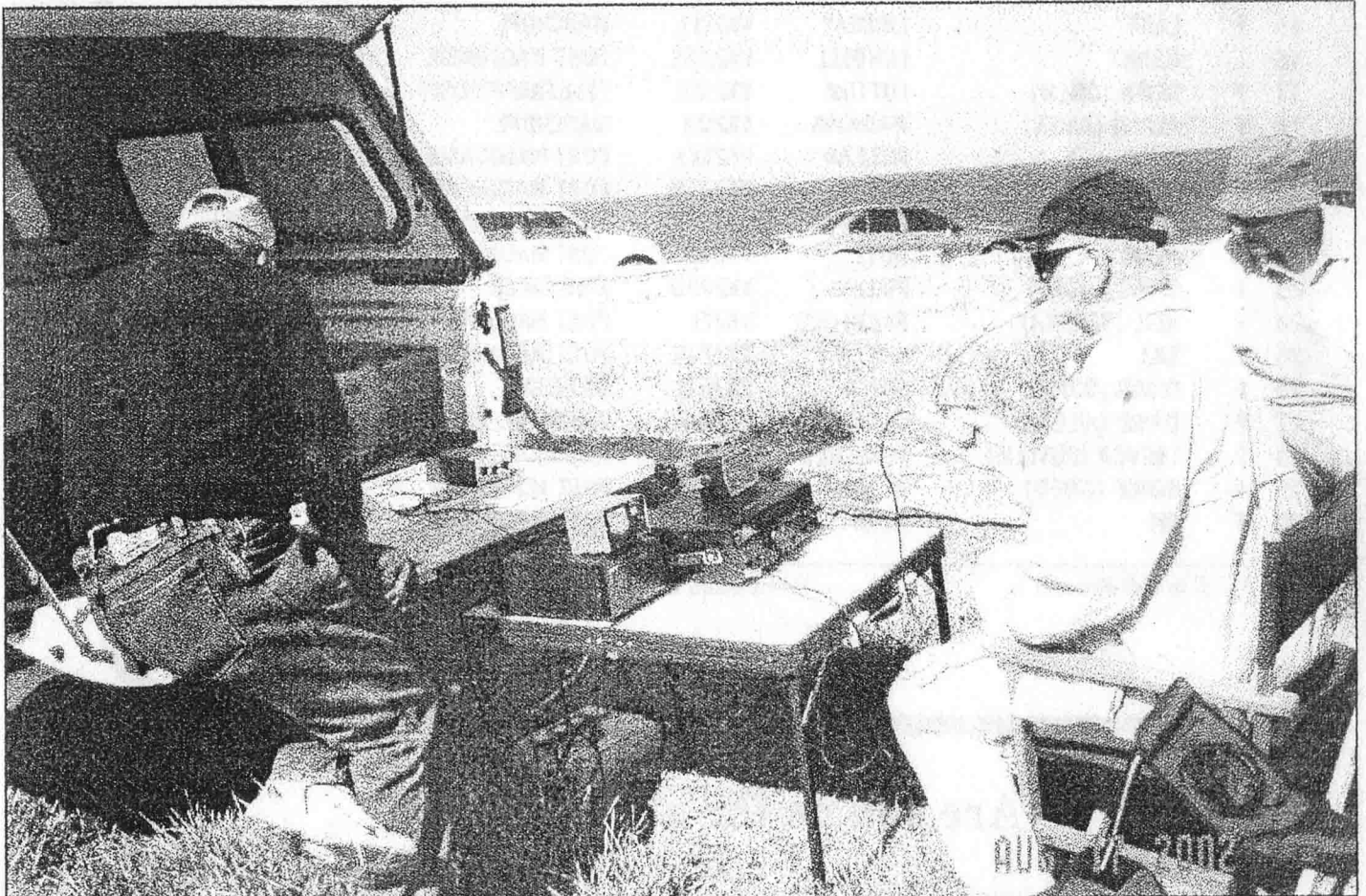

Bob (VK2EJK) scribing for the operator, Alan (VK2GD) with Henry (VK2ZHE), at the ready, as relief staff. ■■■■■■

# OXLEY REGION AMATEUR RADIO CLUB Inc.

## MEMBERSHIP REGISTER.

(as at 2nd September, 2002)

Cat.	FIRST NAME (Spouse)	SURNAME	CALL SIGN	TOWN/CITY	TPH. NO.	
1	F	JOHN (FLORENCE)	BAILEY	VK2KHB	PORT MACQUARIE	02 6582.2192
2	F	JOHN (MARY)	BAYLIS	VK2JB	LAKE CATHIE	02 6585.5703
3	D	ALAN	BELL	VK2BEL	COOLONGLOOK	02 6554.1689
4	F	BOB	BLYTH	VK2XIQ	PORT MACQUARIE	-
5	F	BOB (JOSIE)	BRODIE	VK2EJK	PORT MACQUARIE	02 6582.0592
6	F	BILL (AILSA)	BROOKE	VK2ZCW	PORT MACQUARIE	02 6581.0547
7	F	ROY W (JUNE)	BURGES	VK2YOR	PORT MACQUARIE	02 6583.9349
8	F	KEVIN (JUNE)	COULTER	VK2MAM	PORT MACQUARIE	02 6583.8325
9	F	CHARLES (PAT)	EDMONDSON	VK2FSH	PORT MACQUARIE	02 6584.0495
10	D	STAN (BETTY)	ELLIS	VK2DDL	TUNCURRY	02 6554.7996
11	F	BADEN (VALERY)	GLEESON	VK2MOQ	PORT MACQUARIE	02 6582.2018
12	F	LEWIS (PAMELA)	GREEN	VK2AG	PORT MACQUARIE	02 6584.9162
13	L	KEITH	HANLON	-	PORT MACQUARIE	-
14	F	DAVID (ISOBEL)	HARDING	VK2AIF	WAUCHOPE	02 6586.4980
15	L	LARRY	LINDSAY	VK2CLL	WAUCHOPE	02 6587.1155
16	L	HENRY	LUNDELL	VK2ZHE	PORT MACQUARIE	02 6582.2242
17	F	KEITH (GWEN)	LUTTON	VK2KDL	TELEGRAPH POINT	02 6585.0321
18	F	ALLAN (DAWN)	MADIGAN	VK2OA	WAUCHOPE	02 6585.2043
19	F	JOHN	MCLEAN	VK2KCE	PORT MACQUARIE	02 6583.7400
20	L	ARTHUR (WENDY)	MONCK	VK2ATM	PORT MACQUARIE	02 6583.1311
21	F	LAURIE (ROBIN)	NEWHAM	VK2ELN	PORT MACQUARIE	02 6583.5387
22	F	ALAN	NUTT	VK2GD	PORT MACQUARIE	02 6582.3557
23	F	DAVID A (DEE)	PILLEY	VK2AYD	KING CREEK	02 6585.2647
24	F	NEIL (VERENA)	SANDFORD	VK2EI	PORT MACQUARIE	02 6582.5830
25	F	BILL	SINCLAIR	VK2ZCV	PORT MACQUARIE	02 6583.9302
26	F	DAVID (ROMA)	SMITH	VK2DAL	WAUCHOPE	02 585.1004
27	F	DAVID (AILEEN)	TARRANT	VK2HBC	SPRINGFIELD	02 4365.5046
28	F	TREVOR (PHYLLIS)	THATCHER	VK2TT	WAUCHOPE	02 6585.2278
29	F	BRUCE (GWEN)	WALKER	VK2HOT	PORT MACQUARIE	02 6583.8360
30	F	JIM	WEBSTER	VK2BZD	PORT MACQUARIE	-

F = Full Member

D = Distant Member

L = Life Member

Are you on the above list ?

The club needs your support to make ends meet