

OXTALES

First published 1980

Newsletter of the Oxley Region Amateur Radio Club Inc.

PO Box 712 Port Macquarie 2444

Club e-mail address: vk2bor@orarc.org

Club Website: www.orarc.org

September 2007

Compiled by VK2TT & VK2AYQ

PRESIDENT: Alan Nutt VK2GD 6582.3557
 VICE PRES: Henry Lundell VK2ZHE 6583.8360
 TREASURER: John McLean VK2KCE 6584.6220
 SECRETARY: Jim Neil VK2VIV 6581.2481

President's Report

Long-time active member of our Club, Jim Webster, VK2BZD, passed away suddenly on Monday, 20th August. A good number of our members attended his funeral the following Friday to say our farewells and extend our sympathy to Jim's XYL Mary and son Paul and family.

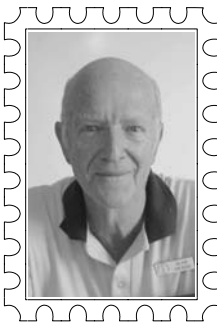

Jim attended our Lighthouse field day only two days before he died and departing this life was probably the last thing on his mind. How suddenly life can be terminated – here one moment, gone the next and all we are left with are memories. He'll be greatly missed.

On more mundane matters, reports to hand indicate our SES friends have finally got things under way for the construction of their new premises. This means we now need to be serious about finding alternative accommodation. Contact with our local Council last week has not proved all that helpful except to confirm that Council does propose to sell the present site. They have little to offer in the way of an alternative meeting place but have given us a number of suggested contacts which we will follow up. The possibility of sharing space with the SES is still not closed off but Council reminded us that any sub-leasing arrange-

ment would need to be included in the SES lease agreement with Council. All suggestions are welcome at this stage.

I have been reminded again recently of the rapidly increasing trend to our becoming a throw-away society. This was brought about as I began the task of clearing out the workshop in preparation to selling our house. I found I had no fewer than five defunct DVD players lying around, all of el-cheapo Chinese manufacture (not all mine, I might add.). Each had suffered a power supply failure and none had originally cost more than \$70. Later, trying to find some replacement IC's on the Web, I came across a DVD user-group where someone had commented that none of these cheap devices appears to last more than four to six months. I can verify that observation but it's taking built-in obsolescence a bit too far for my liking. I can't see any smart answer to this one but it certainly plays havoc with our electronic service industry..

- Alan Nutt VK2GD
 El Presidentè

In This Issue :

Item.	Page No.
President's Report	Front Cover
Down the Coax	2
E-Mail Directory	2
Net Controllers' Roster	2
For Sale	2
Audio Interface	3
There IS an Explanation!	4
New Harmonic!	4
SK Vale Jim Webster VK2BZD	5
2007 AGM Report	6
Lighthouse Weekend Report	6
Remembrance Day Report	7
Membership Register	Rear Cover



Down The Coax

Friday Night Get-togethers
September 14th & 28th 7.00pm

October Monthly Meeting
Sat. 6th October at 2.00pm

Jota
Sat/Sun October 20th & 21st

Beechwood Billy Cart Classic
Sunday 21st October

Friday Night Get-togethers
October 12th & 26th 7.00pm

November Monthly Meeting
Sat. 3rd November at 2.00pm

E-mail directory.

*Reflects ALL changes notified up to
26th October, 2007*

VK2EI (Neil) neilsan@tpg.com.au
VK2EM (Bruce) brucee@iprimus.com.au
VK2GD (Alan) anu16734@bigpond.net.au
VK2TT (Trevor) grumps@midcoast.com.au
VK2YB (Roy) identity@midcoast.com.au
VK2ATM (Arthur) arfamo@midcoast.com.au
VK2AYD (David) dvdply@midcoast.com.au
VK2AYQ (John) hansenjo@ozemail.com.au
VK2BAL (Les) lnbjanes@tpg.com.au
VK2BEL (Allan) belly@tsn.cc
VK2BOR (ORARC) vk2bor@westnet.com.au
VK2CJM (Chris) Chris@CalmDowns.org.au
VK2CHC (Richard) farmsale@midcoast.com.au
VK2CLL (Larry) lindsay@midcoast.com.au
VK2DDL (Stan) svellis@tsn.cc
VK2EJK (Bob) rbr01962@bigpond.net.au
VK2FSH (Charles) cpedmond@felglow.com.au
VK2HOT (Bruce) vk2hot@tsn.cc
VK2IEV (Joe) bivona@aapt.net.au
VK2KCE (John) hrbe@bigpond.net.au
VK2DMX (Steve) haddie_007@hotmail.com
VK2TMG (Brett) breree@gmail.com
VK2TRM (Graham) emu@midcoast.com.au
VK2VIV (Jim) jim.neil@gmail.com
VK2YOR (Roy) rburges@intercoast.com.au
VK2ZCM (Craig) vk2zcm@dodo.com.au
VK2ZCV (Bill) wsi54224@bigpond.net.au
VK2ZCW (Bill) cabrooke@westnet.com.au
VK2ZHE (Henry) lundell@tpg.com.au
VK2ZIS (Graeme) admiral@midcoast.com.au
VK2ZTM (Tim) c/- info@tvq.com.au
VK2FABJ (Ailsa) cabrooke@westnet.com.au
VK2FBRG (Barry) fgilson@bigpond.net.au
VK2FJKD (Jim) jaidanl@bigpond.com
VK9FLHI (Des) lhibluelag@bigpond.com

Net Controllers' Roster

Nets on Voice Repeater VK2RPM 146.700 Mhz

Sundays
(0830 Local)

Wednesdays
(1930 Local)

September 2007

VK2VIV	Sep-02	VK2EI	Sep-05
VK2TT	Sep-09	VK2AYD	Sep-12
VK2OA	Sep-16	VK2GD	Sep-19
VK2VIV	Sep-23	VK2ZCM	Sep-26
VK2TT	Sep-30		

October 2007

VK2OA	Oct-07	VK2ATM	Oct-03
VK2VIV	Oct-14	VK2ZHE	Oct-10
VK2TT	Oct-21	VK2EI	Oct-17
VK2AO	Oct-28	VK2AYD	Oct-24
			Oct-31

November 2007

VK2VIV	Nov-04	VK2GD	Nov-07
VK2TT	Nov-11	VK2ZCM	Nov-14
VK2OA	Nov-18	VK2ATM	Nov-21
VK2VIV	Nov-25	VK2ZHE	Nov-28

December 2007

VK2TT	Dec-02	VK2EI	Dec-05
VK2OA	Dec-09	VK2AYD	Dec-12
VK2VIV	Dec-16	VK2GD	Dec-19
VK2TT	Dec-23	VK2ZCM	Dec-26
VK2OA	Dec-30		

January 2008

VK2VIV	Jan-06	VK2ATM	Jan-02
VK2TT	Jan-13	VK2ZHE	Jan-09
VK2OA	Jan-20	VK2EI	Jan-16
VK2VIV	Jan-27	VK2AYD	Jan-23
		VK2GD	Jan-30

February 2008

VK2TT	Feb-03	VK2ZCM	Feb-06
VK2OA	Feb-10	VK2ATM	Feb-13
VK2VIV	Feb-17	VK2ZHE	Feb-20
VK2TT	Feb-24	VK2ZEI	Feb-27

For Sale

YAESU FT-690R MK2
VHF All mode (FM-USB/LSB-CW)
6 Metre 50-54 MHz
2.5W O/P
Portable or Base Station
Very good condition
Complete with:-
Portable antenna (Telescopic Whip)
Mike (Hand)
Handbook
\$150 O.N.O.

Contact VK2AIF 02 6586 4980

Audio Interface

An audio interface between Computer and Transceiver is necessary for all digital communication modes. Practical experience has shown that in almost all cases the two devices need to be electrically isolated from each other to avoid distortion and hum loops from common ground paths.

There are several ways to do this, but two of the most common are using audio isolation transformers or opto coupler devices. The Tx/Rx switching can be done using the audio tones to activate the vox circuits in the Transceiver or using the PTT line to hard switch the transceiver. If using the PTT circuit, this also must be isolated to avoid common earth problems.

If using audio transformers, care must be taken to use high quality ones with linear transfer characteristics. Use of a level adjustment network on the input is advisable to avoid saturation of the core with subsequent distortion of the audio waveform.

If using opto couplers, a small biasing current is needed to turn on the led and photo transistor combination to ensure class "A" linear transfer.

If using the PTT line then a transistor switched relay will provide isolation. Power for the circuits must be provided separately by the computer and transceiver or by a separate isolated power supply.

Audio output from soundcard to transceiver should, if possible be taken from the headphone socket, rather than the speaker out socket to achieve a better impedance match. The audio in from transceiver to soundcard should use the Line_in socket rather than the Mic_in socket.

The circuits shown are for both systems and are ones I have built and used successfully for PSK31, SSTV, RTTY, MCW, and all other digital modes.

— de VK2ATM

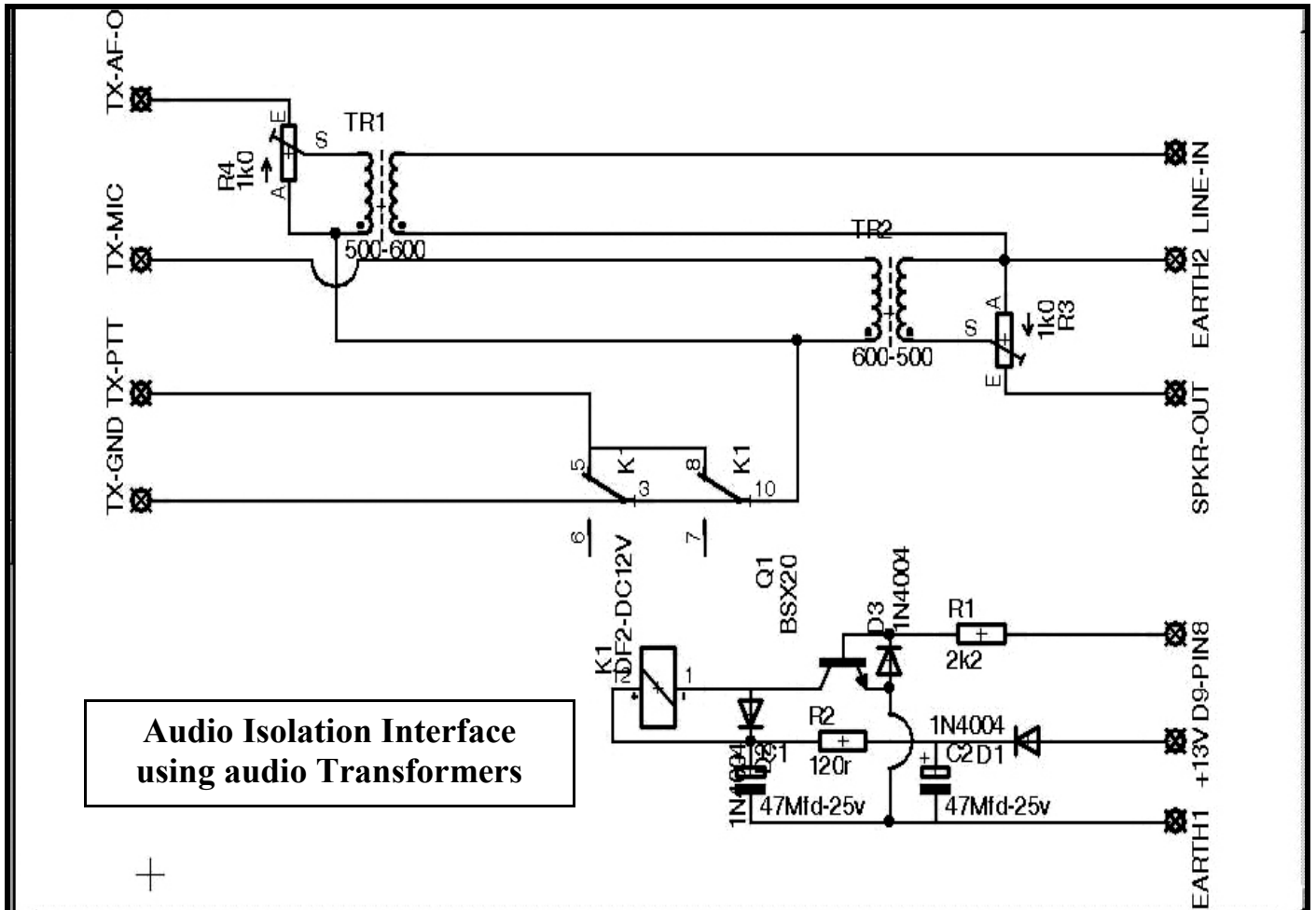

See next page for Opto-coupler version

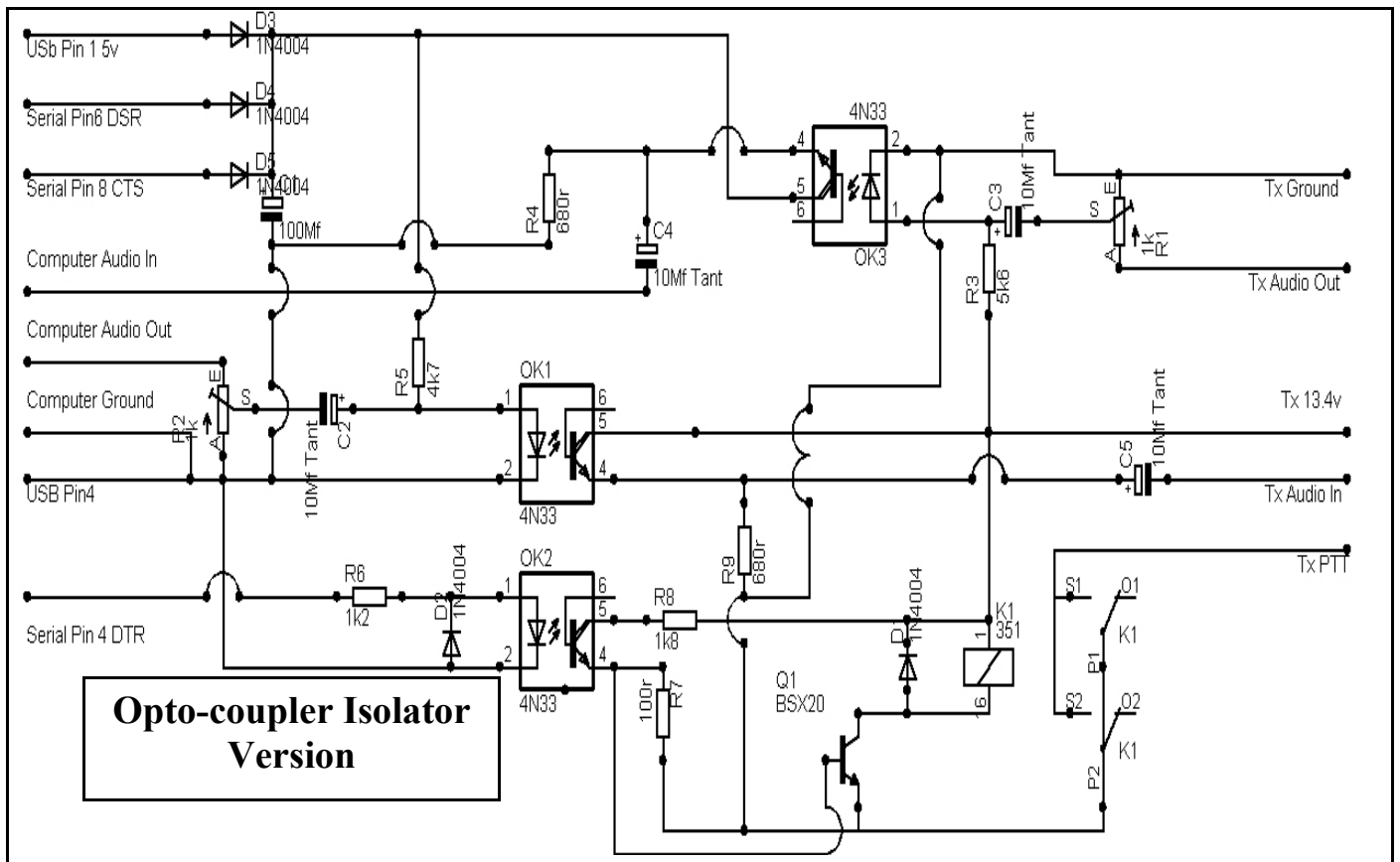

There IS an Explanation!

The "FFFF" item in July OXTALES, on page 3, does have an explanation. The phenomenon occurs when a light fitting has the mains active and neutral supply wired direct to the fitting and the wiring to the switch is run as two paired wires (unswitched active and switched active) between the light fitting and the switch ie, the active is looped at the switch.

Most modern compact fluorescent lamps (CFL) employ a switched mode DC-AC inverter type ballast. Consequently the input to the lamp consists of a diode bridge which rectifies the incoming mains to feed the inverter with DC.

Naturally there is a filter capacitor across the output of the rectifier to smooth the DC which runs the inverter. When the switch is turned off the capacitance between the two wires to the switch is sufficient to support enough 50 Hz AC current to slowly charge the filter capacitor. When the voltage across the capacitor is sufficient to start the inverter oscillator, the inverter starts up and there is brief flash of light from the CFL tube as the switched mode inverter starts and quickly discharges the filter capacitor.

As the current charging the capacitor is very low, the resultant flash of light is brief and not very intense, and it takes a significant time for the capacitor to build up enough voltage to repeat the cycle. For this reason the effect is only noticeable in a darkened

room. The earlier CFLs which used a passive iron cored ballast would of course not flash but would simply glow very dimly. This steady dim glow sometimes occurs in conventional ballasted fluorescent tubes under the same circumstances.

- Henry (VK2ZHE)

Club Member's New Harmonic!

Brett Rees (VK2TMG) and XYL, Yvette, have been blessed with the arrival of Delia May, a fine 4.83 Kg baby girl, on 13th August.

It has been quite some time since a club member has enjoyed the happy arrival event of a new family member. ALARA can look forward to a prospective new member a little further down the track!

Congratulations Brett and Yvette! and Welcome Delia!



Cute eh?



**Silent Key
James Barber Webster VK2BZD
(Jim)**

It is with deep regret that we record the sudden passing of James Barber Webster, VK2BZD, at Port Macquarie on Monday 20th August 2007. He was known as Jim to his many friends. Jim was in his 85th year.

Jim was born in Merewether, the son of George Ernest Barber Webster. George was an engineer in the Army.

During his formative years Jim's family moved from Waratah, where George had built a house, to Duntroon, then to Victoria Barracks at Paddington. This was followed by two years in Brisbane before the family moved back to Sydney where George built another house in Kingsford in 1939.

While his parents were in Brisbane, Jim stayed with his aunt in Newcastle to complete his last two years of school at Newcastle Boys High, where he was a prefect.

Jim majored in physics at university in Sydney where he completed a Science degree in 1941. He was a member of the University Regiment where he helped as he could with the war effort but could not enlist on graduation because he was automatically drafted into munitions and worked on optics. It was while he was doing this work through the university that Jim met Mary whom he married in 1948.

After the war Jim became a teacher. Following country postings to Grenfell and Gilgandra, he returned to Sydney as Science Master at Homebush and Birrong High Schools.

In retirement Jim and his wife, Mary, settled in Port Macquarie where their son, Paul VK2BZC, and daughter-in-law had earlier moved to practice medicine.

Jim had a deep interest in all things scientific. He was very practical and had craftsman skills in both metal and wood. He particularly enjoyed metal turning on his lathe.

Amateur Radio played a very important part in Jim's life. In Sydney he was very active in the Youth Radio Scheme and ran the radio club at Birrong High School. He supported the St George Amateur Radio Society as well as the WIA. He was an active WICEN member and participated in emergency communications for disasters such as the Royal National Park bushfires and the Newcastle earthquake. He could always be counted on to participate in WICEN training exercises such as

the City to Surf and the Hawkesbury Canoe Classic. Jim's preparedness and professional approach to communications always set a high standard.

When he came to Port Macquarie, Jim enthusiastically participated in the activities of the Oxley Region Amateur Radio Club. He rarely missed a meeting and was always first to volunteer to assist with tasks. He participated in the operation of the club station VK2BOR at the Tacking Point Lighthouse only two days before passing away.

Jim will always be remembered for his willingness to help others. He was always respected for his reliability and his unassuming manner of so freely sharing his vast knowledge.

Jim's funeral service was held on Friday 24th August 2007 in the chapel of the Port Macquarie Crematorium. His son Paul VK2BZC delivered a heartfelt eulogy.

This Silent Key has been compiled from the eulogy which Paul so kindly provided. Thank you Paul.

Deepest sympathy is extended to Jim's wife Mary, and to all his family in their sad loss.

Vale James Barber Webster VK2BZD (Jim)

—Henry Lundell — VK2ZHE

2007 AGM Report

ORARC's AGM for the year 2007-2008, held on Saturday August 4th, saw a good attendance by the membership at our Gordon Street Club Rooms.

There were very few changes to the structure of the office bearers, with Henry – VK2ZHE – taking on the Vice Presidency to replace Bruce - VK2HOT- who wished to stand down from that post, a couple of swaps within the other positions, and a new committee member, Craig—VK2ZCM. Election results, listed below, show the new office bearers:

President	Alan Nutt.	VK2GD
Vice President	Henry Lundell	VK2ZHE
Secretary	Jim Neil	VK2VIV
Treasurer	John McLean	VK2KCE
Committee Member 1	Bill Sinclair	VK2ZCV
Committee Member 2	Bill Brooke	VK2ZCW
Committee Member 3	Craig Martin	VK2ZCM
Public Officer	Roy Burges	VK2YOR
Auditor	V. Hume	
Repeater Chairman	Bill Brooke	VK2ZCW
Oxtales Editors	Trevor Thatcher	VK2TT
	John Hanson	VK2AYQ
VK2BOR Station Manager	Bruce Walker	VK2HOT
Welfare Officer	Bill Sinclair	VK2ZCV
Publicity Officer	Bill Brooke.	VK2ZCW
Education Officer	Larry Lindsay	VK2CLL
Equipment Officer	Barry Gilson	VK2FBRG
Club Historian	John Bailey	VK2KHB
Social Director	Barry Gilson	VK2FBRG
WIA Liaison Delegate	David Pilley	VK2AYD

And now we have set sail into 2007-2008, at full speed ahead.

International Lighthouse and Lightship Weekend (Sat/Sun 18 & 19 August 2007)

VK2BOR operated portable on Saturday 18 August 2007, from the reserve at the Tacking Point Lighthouse AUS 158, Port Macquarie

The participants were:

Arthur Monck	VK2ATM
Steve Hadfield	VK2DMX
Barry Gilson	VK2FBRG
John Hansen	VK2AYQ
Larry Lindsay	VK2CLL
Craig Martin	VK2ZCM
Adam Martin	-
John McLean	VK2KCE
Des Thompson	VK9FLHI
Paul Jones	VK2DEL
Bob Brodie	VK2EJK
Jim Webster	VK2BZD
Bill Brooke	VK2ZCW
Bill Sinclair	VK2ZCV
Alan Nutt	VK2GD
Henry Lundell	VK2ZHE

VK4WIN Pine Islet, VK3TEX Kyabram, VK3EG Point Hicks (AUS133), VK4BAR Cleveland Point (AUS 130), VK4BOI Noosa, VK2BEL, Sugarloaf Point, Seal Rocks, VK4BW Burnetts Head old lighthouse, VK4WIS Old Caloundra, VK2EBR Cundletown, VK2ILH Smokey Cape, VK3WI Williamstown, VK3ANR Geelong, VK5BWR Lowly Points, Whyalla, VK2FREK Warden Head, VK3GER Eastern Lighthouse McCrae, VK3ILH Currie Lighthouse King Island, VK5VGC Kapunda, VK2KLB Pambula, VK2BJ/M Berry. All the foregoing stations were worked on the 40M band. On the 20M band, contacts were made with ZL6LH Manukau Heads, and VK4VAP Kelso.

Thank you to everyone. The many willing hands made quick work of setting up and dismantling the station. The operation was a great success with a fine day and good band conditions. Special thanks to Steve, VK2DMX, for bringing his trailer. It made transporting all the equipment very easy this year.

— Henry—VK2ZHE

Throughout the group's period of operation, from 0019 UTC—0415 UTC on the 18th, they collected a good haul of contacts, which included: VK2ATZ Nora Head (AUS 119),

See pictures on the next page for this event and the RD contest, submitted by Bill—VK2ZCW.

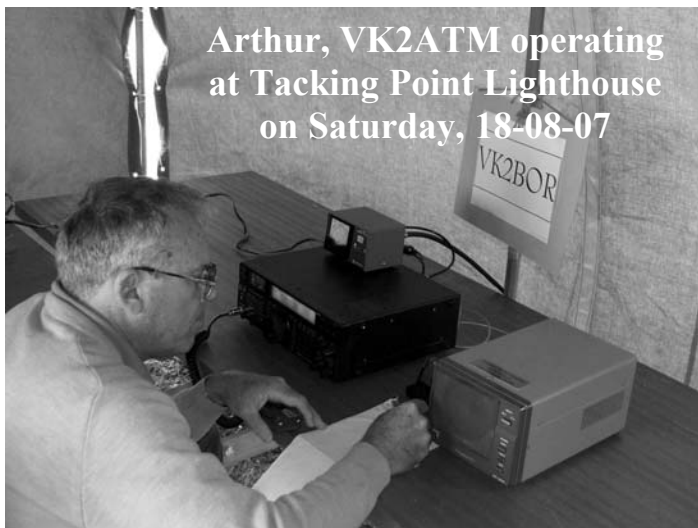

Arthur, VK2ATM operating at Tacking Point Lighthouse on Saturday, 18-08-07



View of the operating site from Tacking Point Lighthouse Saturday 18-08-07

Remembrance Day Contest

Club members were also active on the occasion of Remembrance Day. Over the weekend of 11/12th August, operating from VK2ZHE's comfortable shed location, at Port Macquarie, fifteen members participated in taking turns at the operating position. Those members taking part were:

Neil Sandford
 Bill Sinclair
 Barry Gilson
 Steve Hadfield
 John Bailey
 Bruce Walker
 Jim Neil

VK2EI
 VK2ZCV
 VK2FBRG
 VK2DMX
 VK2KHB
 VK2HOT
 VK2VIV

Bill Brooke
 John Hansen
 Paul Graham
 Alan Nutt
 John McLean
 Des Thompson
 Craig Martin
 Henry Lundell

VK2ZCW
 VK2AYO
 VK2FPRG
 VK2GD
 VK2KCE
 VK9FLHI
 VK2ZCM
 VK2ZHE

At the time of going to press, our score was not available, but details will appear in our next issue.



(Left)
 Barry—VK2FBRG & Joe—VK2IEV
 At the operating table in Henry's Shack



(Right)
 A change of role for Barry and Joe when they became caterers, after their operating stint. Neil—VK2EI, in the background, is responsible for total quality control.



OXLEY REGION AMATEUR RADIO CLUB Inc.

MEMBERSHIP REGISTER.

(As at 29th August 2007)

Cat.	Surname	Given	Spouse Name	Call	Location	Tph
1	O BAILEY	JOHN	(FLORENCE)	VK2KHB	PORT MACQUARIE	02 6582.2192
2	D BELL	ALAN		VK2BEL	COOLONGLOOK	02 6554.1689
3	O BIVONA	JOE	(ROSE)	VK2IEV	PORT MACQUARIE	0405 040 953
4	L BLYTH	BOB		VK2XIQ	PORT MACQUARIE	-
5	O BRODIE	BOB		VK2EJK	PORT MACQUARIE	02 6582.0592
6	O BROOKE	AILS A	(BILL)	VK2FABJ	PORT MACQUARIE	02 6581.0547
7	O BROOKE	BILL	(AILS A)	VK2ZCW	PORT MACQUARIE	02 6581.0547
8	O BURGES	ROY	(JUNE)	VK2YOR	PORT MACQUARIE	02 6583.9349
9	O COULTER	KEVIN	(JUNE)	VK2MAM	PORT MACQUARIE	02 6583.8325
10	O COURT	RICHARD	(LINDA)	VK2CHC	BEECHWOOD	02 6585.6866
11	O DANIEL	JIM		VK2FJKD	PORT MACQUARIE	02 6583.1933
12	D EKERT	BRUCE	(SUE)	VK2EM	EAST MAITLAND	02 4934 3025
13	D ELLIS	STAN	(BETTY)	VK2DDL	TUNCURRY	02 6554.7996
14	O EDMONDSON	CHARLES	(PAT)	VK2FSH	PORT MACQUARIE	02 6584.0495
15	O GILSON	BARRY	(FAY)	VK2FBRG	PORT MACQUARIE	02 6583.8814
16	O GLEESON	BADEN	(VALERY)	VK2MOQ	PORT MACQUARIE	02 6582.2018
17	O GREEN	LEWIS	(PAMELA)	VK2AG	PORT MACQUARIE	02 6584.9162
18	A GRAHAM	PAUL	(JANE)	VK2FPRG	WAUCHOPE	02 6586.4720
19	O GREENWOOD	GRAEME		VK2ZIS	MIDDLE BROTHER	02 6559.4836
20	O HADFIELD	STEVE		VK2DMX	PAPPINBARRA	02 6587.6160
21	L HANLON	KEITH		-	PORT MACQUARIE	-
22	O HANSEN	JOHN		VK2AYQ	PORT MACQUARIE	02 6582.7932
23	O HARDING	DAVID	(ISABELLA)	VK2AIF	WAUCHOPE	02 6586.4980
24	O JANES	LES		VK2BAL	PORT MACQUARIE	02 6583.3789
25	L LINDSAY	LARRY		VK2CLL	WAUCHOPE	02 6587.1155
26	L LUNDELL	HENRY		VK2ZHE	PORT MACQUARIE	02 6582.0534
27	O MADIGAN	ALLAN	(DAWN)	VK2OA	WAUCHOPE	02 6585.2043
28	O MARRIOTT	JOHN	(ROSE)	VK2CIF	NORTH HAVEN	02 6559.9245
29	O MARTIN	CRAIG	(JENNY)	VK2ZCM	SANCROX	02 6585.3452
30	O MCLEAN	JOHN	(CORRINE)	VK2KCE	PORT MACQUARIE	02 6584.6220
31	O MEEHAN	TERRY		VK2KL	PORT MACQUARIE	02 6584.2997
32	D MILLS	TIM		VK2ZTM	BEECROFT	02 9868.1434
33	H MINAHAN	CHRIS		VK2EJ	HALLIDAYS POINT	02 6559.3516
34	L MONCK	ARTHUR	(WENDY)	VK2ATM	PORT MACQUARIE	02 6581.0960
35	O NEIL	JIM	(CAROL)	VK2VIV	PORT MACQUARIE	02 6581.2481
36	O NEWHAM	LAURIE	(ROBIN)	VK2ELN	PORT MACQUARIE	02 6583.5387
37	O NUTT	ALAN	(ELAINE)	VK2GD	PORT MACQUARIE	02 6582.3557
38	O PILLEY	DAVID	(DEE)	VK2AYD	KING CREEK	02 6585.2647
39	O REES	BRETT	(YVETTE)	VK2TMG	PORT MACQUARIE	02 6582.5956
40	O RICHTER	ROY		VK2YB	VIA WAUCHOPE	02 6587.4232
41	O ROTH	BILL		VK2CWR	PORT MACQUARIE	02 6581.1776
42	O SANDFORD	NEIL	(VERENA)	VK2EI	PORT MACQUARIE	02 6582.5830
43	L SINCLAIR	BILL		VK2ZCV	PORT MACQUARIE	02 6583.9302
44	D TARRANT	DAVID	(AILEEN)	VK2TBC	ILUKA	-
45	O THATCHER	TREVOR		VK2TT	WAUCHOPE	02 6585.2278
46	D THOMPSON	DES	(BETTY)	VK9FLHI	LORD HOWE ISLAND	02 6563 2152
47	O WALKER	BRUCE	(GWEN)	VK2HOT	PORT MACQUARIE	02 6583.8360

Category Key: O = ORDINARY A = ASSOCIATE D = DISTANT H = HONORARY L = LIFE